

Wavelet Based De-noising of Current Harmonics for Identification

Shweta Gupta¹, A K Sharma²

^{1,2}Electrical Engineering Department Jabalpur Engineering College, Jabalpur, India

Abstract: In this paper we used wavelet transform which is useful in signal processing. Wavelet transform is used for analyze different power quality events. The power quality events like pure sine voltage wave, voltage sag, swell, harmonics, impulse can obtained using wavelet transform. The wavelet algorithm is a useful tool for signal processing. Fourier transform is also used for denoising but limited to stationary signals .For continuous analysis of non-stationary signals wavelet transform is used. The presence of noise can be detected by wavelet methods and analyze the noisy signal. The noisy signal can be denoised using wavelet transform.

Keywords: Power quality, Harmonics, Noise, Wavelet Transform.

1. INTRODUCTION

Wavelet transform is a powerful tool of signal and image processing that have been used in many applications such as signal processing, image compression and pattern recognition [1]. Fourier transform is a powerful tool which is widely used in signal analysis and processing. But this traditional method is not applicable for non-stationary signals. To overcome this difficulty, this method is improved into Short Time Fourier Transform (STFT). By applying this on each and every parts of signal, there is a drawback of inflexibility of time frequency resolution. This is unsuitable for nonstationary signals like over voltage signals. The wavelet transform overcome these problems and used to detect various fault in power system [2]. Wavelets are currently used for signal denoising. Wavelet denoising is used to remove the noise present in the signal .It involves three steps:-a wavelet transform, thresholding and an inverse Wavelet transform ,where the input signal consider with some additive noise[1]. In power system the wavelet transform is used for fault detection, disturbance detection denoising of electrical signals and data compression in power quality monitoring [3].

2. POWER QUALITY

Power quality has become an important issue in recent time when many utilities around the world find very difficult to meet energy demand which leads to load shedding and power quality problem. The power quality problems is an occurrence of a non standard frequency ,voltage, and current that results in a mal-operation of end user equipments .In distribution networks ,sensitive industrial loads and critical commercial operations suffer from types of outages and service interruptions, which can cost significant financial losses. Today's modern industrial devices are commonly based on electronic devices such as programmable logic controllers and electronic devices. The electronic device are very sensitive to disturbances and become less tolerant to power quality problems such as voltage sags or dips, swells and harmonics [4],[17].

The main source of power quality problems is the high power non-linear industrial loads. Rapid variations in real and reactive power drawn by such loads causes rapid current variations, which are repetitive in nature, and result in the distortion of the voltage waveform. Customers who are connected to the same network and who are in close proximity to these large nonlinear loads are subjected to transient disturbances, manifesting in the form of flicker and other effects in

the functioning of electrical equipment. The distortion in the quality of supply power can be introduced/ enhanced at various stages; however, source of the primary sources of distortion can be identified as below.

- Power Electronic Devices
- Arcing Devices
- IT and Office Equipments
- Load Switching
- Large Motor Starting
- Embedded Generation
- Electromagnetic Radiation and Cables [5],[6]

POWER QUALITY PROBLEMS ARE:

- Harmonics Distortion
- Voltage Swell, Sag/Dips, Voltage unbalance, Flicker and Transients
- Voltage Magnitude and Frequency, Voltage Fluctuation
- Hot Grounding Loops
- Ground Potential Rise
- Measurement and Management of quasi-dynamic, quasi-static and Transient type phenomena [6].[10]

SOLUTION TO IMPROVE POWER QUALITY PROBLEMS:

To mitigate the above mentioned power quality problems various generalized methods have been suggested in the literature. Various method have been proposed to detect and localize the power quality events such as Discrete Fourier Transform (DFT), Short Time Fourier Transform (STFT), and Wavelet Transform. One of the important methods to reduce noise in various signals is Wavelet transform. Wavelet Transforms have emerged a fast and effective tools for automated detection and effective characterization of PQ disturbances .Discrete Wavelet Transform (DWT) based multi resolution analysis (MRA), which is used as multi resolution decomposition in PQ literature, analyze the signal at different frequencies with different resolutions [8].

To improve the power quality there are different ways to mitigate voltage dips, swell in transmission and distribution systems. At present, a wide range of very flexible controllers are emerging in power applications .Among these, the distribution static compensator is most effective devices, which is based on VSC principle. A new PWM control scheme has been implemented to control the electronic valves in two level VSC used in D-STATCOM. The term power quality ,broadly refers to maintain sinusoidal bus voltage at rated magnitude and frequency in an uninterrupted manner from the reliability point of view. For a well designed generating plant generates voltages almost perfectly sinusoidal at rated magnitude and frequency. Power quality problems start with transmission system and stay valid until end user in distribution system [7].

3. WAVELET

A wavelet is an oscillating function of time or space and it is periodic in nature, where wavelets are localized wave and their energy is concentrated in time or space.

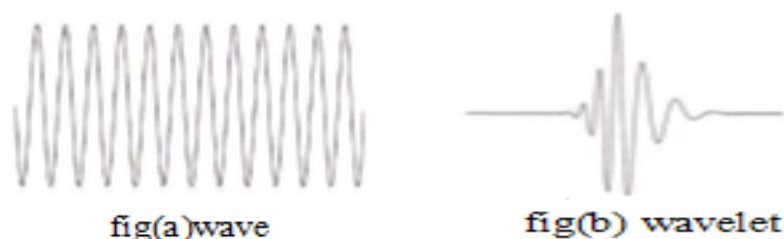

Fig (1)

By comparing Fourier Transform and STFT, Wavelet Transform uses wavelets of finite energy. The Wavelet Transform provides better time-frequency representation of the signal by using a multi-resolution technique in which different frequencies are analyzed under different resolutions [8], [9].

WAVELET TRANSFORM:

The basic idea of the wavelet transform is to represent any arbitrary function $f(t)$ as a superposition of a set of such wavelets or basis functions. These basis functions or baby wavelets are obtained from a single prototype wavelet called the mother wavelet, by dilations or contractions (scaling) and translations (shifts) [8].

CONTINUOUS WAVELET TRANSFORM:-

The Continuous Wavelet Transform (CWT) is represented by Equation, where $x(t)$ is the signal and $\psi(t)$ is the mother wavelet or the basis function $XWT(\tau,s) = 1/\sqrt{|s|} \int x(t) \cdot \psi^*(t-\tau/s) dt$ (1)

where “ τ ” is the translation parameter corresponds to the time information, „ s ” is the scale parameter relates to the frequency information. The scaling parameter provides detailed information of the signal through large scale and global information of the signal from small scale parameter. A wavelet is represented by two orthogonal functions: the scaling function or father wavelet “ $\phi(t)$ ” & wavelet function or mother wavelet, “ $\psi(t)$ ”.

The scaling and wavelet functions satisfy,

$$\int_{-\infty}^{\infty} \phi(t) dt = z$$

and

$$\int_{-\infty}^{\infty} \psi(t) dt = 0 \tag{2}$$

Where “ z ” is a constant and Equation(2) signifies that wavelet function is localized.

The energies of these functions are finite, which means

$$\int_{-\infty}^{\infty} |\phi(t)|^2 dt < \infty$$

and

$$\int_{-\infty}^{\infty} |\psi(t)|^2 dt < \infty \tag{3}$$

The scaling function and the mother wavelet are orthogonal to each other:

$$\int_{-\infty}^{\infty} \phi * (t)\psi(t) dt = 0 \tag{4}$$

The complete set of basis function generated by translation and shifting of $\phi(t)$ and $\psi(t)$ [8],[11].

DISCRETE WAVELET TRANSFORMS (DWT): Compared to the CWT, DWT provides the sufficient information about the signal and reduces the computation time. In case of CWT, multi-resolution analysis of the signal performed by scaling and translation of the wavelet functions. But DWT is a fast linear operation in which digital filters are used with different cutoff frequencies to analyze time-scale representation of the digital signal. These filter banks decompose the signal into an approximate coefficient (low frequency components) and detailed coefficients (high frequency components). In 1988, S. Mallat represents the scale and translation in power of two also called dyadic scale and translation, which give a better analysis of the signal. DWT represents the length in power of two where wavelet function represents

$$\psi_{(i,j)}(x) = 2^{j/2} \psi(2^j x - k) \tag{5}$$

The scaling function is given as

$$\phi_{(i,j)}(x) = 2^{j/2} \phi(2^j x - k) \tag{6}$$

Where „ ψ^* “ is called the wavelet function and j , k represents the scale index and position respectively. In terms of the wavelet coefficients and scaling coefficients

$$\psi(x) = \sum_k^{N-1} Gk \sqrt{2\phi(2x - k)} \quad (7)$$

Where $G_0, G_1, G_2 \dots$ are high pass wavelet coefficients

$$\phi(x) = \sum_k^{N-1} Hk \sqrt{2\phi(2x - k)} \quad (8)$$

Where $H_0, H_1, H_2 \dots$ are low pass scaling coefficients [3].

WAVELET PACKET DECOMPOSITION:- WPT is a generalization of wavelet decomposition that offers a wider range of possibilities for signal analysis. WPT is an expansion of classical wavelet decomposition that presents more complex and flexible analysis because in WPT analysis the Details (D) as well as the Approximations (A) are separated like complete binary tree. For each level of decomposition, the signal is filtered into approximation information of the signal which contain lower frequency component and detail information which contain lower frequency component. Figure shows the wavelet packet decomposition tree obtained up to 3 level of decomposition [8].

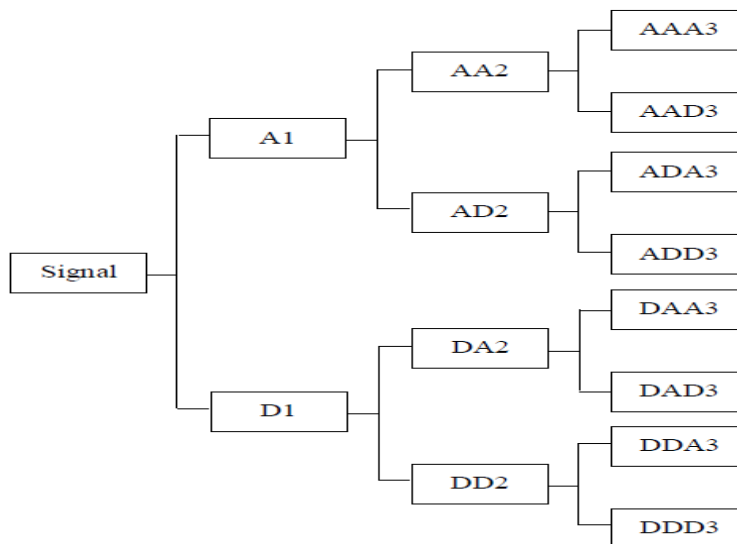

Fig (2) Wavelet Packet Decomposition Tree

WAVELET THRESHOLDING:

Wavelet thresholding (first proposed by Donoho) is a signal estimation technique that exploits the capabilities of wavelet transform for signal denoising. It removes noise by killing coefficients that are insignificant relative to some threshold.

Researchers have developed various techniques for choosing denoising parameters and so far there is no “best” universal threshold determination technique.

SOFT AND HARD THRESHOLDING:

Signal denoising using the DWT consists of the three successive procedures, namely, signal decomposition, thresholding of the DWT coefficients, and signal reconstruction. Firstly, we carry out the wavelet analysis of a noisy signal up to a chosen level N. Secondly, we perform thresholding of the detail coefficients from level 1 to N. Lastly, we synthesize the signal using the altered detail coefficients from level 1 to N and approximation coefficients of level N. However, it is generally impossible to remove all the noise without corrupting the signal.

As for thresholding, we can settle either a level-dependent threshold vector of length N or a global threshold of a constant value for all levels. According to D. Donoho’s method, the threshold estimate δ for denoising with an orthonormal basis is given by

$$\delta = \sigma \sqrt{2 \log L} \quad (9)$$

Where the noise is Gaussian with standard deviation σ of the DWT coefficients and L is the number of samples or pixels of the processed signal or image. This estimation concept is used by Matlab. From another point of view, thresholding can be either *soft* or *hard*. Hard thresholding zeroes out all the signal values smaller than δ . Soft thresholding does the same thing, and apart from that, subtracts δ from the values larger than δ . In contrast to hard thresholding, soft thresholding causes no discontinuities in the resulting signal. In Matlab, by default, soft thresholding is used for denoising and hard thresholding for compression [14],[15].

Hard threshold: $y = x$ if $|x| > T$

$$y = 0 \text{ if } |x| < T \quad (10)$$

Soft threshold: $y = \text{sign}(x) (|x| - T)$ (11)

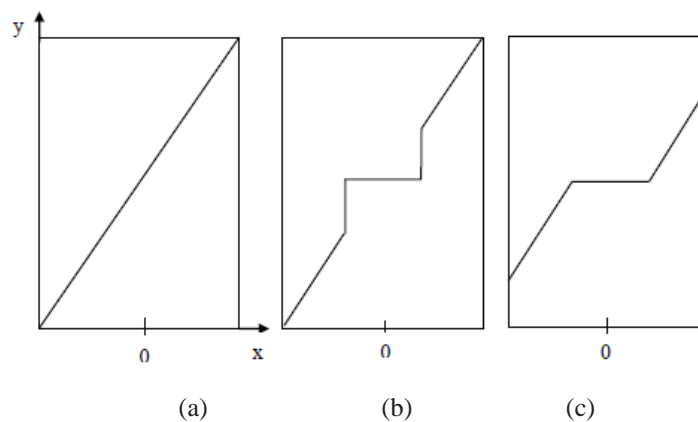

Fig (3) Thresholding of signal

(a) Original signal (b) Hard threshold (c) Soft threshold

WAVELET DENOISING:

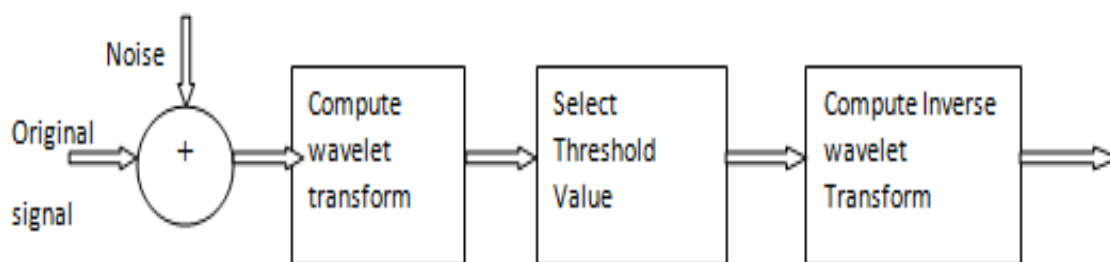

Fig (4) Wavelet Denoising Block Diagram

The general wavelet denoising procedure is as follows

- Apply wavelet transform to the noisy signal to produce the noisy wavelet coefficients to the level which we can properly distinguish the noise occurrence.
- Select appropriate threshold limit at each level and threshold method (hard or soft thresholding) to best remove the noises.
- Inverse wavelet transform of the threshold wavelet coefficients to obtain a denoised signal [12],[16].

APPLICATION OF WAVELET TRANSFORM IN OTHER FIELDS OF POWER SYSTEM:-

Wavelet transform has been implemented in following several fields of power system in last few years

- Power quality
- Power system protection
- Power system transients
- Partial discharge
- Load forecasting
- Power system measurements [11], [2].

4. DESIGN AND SIMULATION

This model created to generate the input voltage and current signal which is applied to the process.

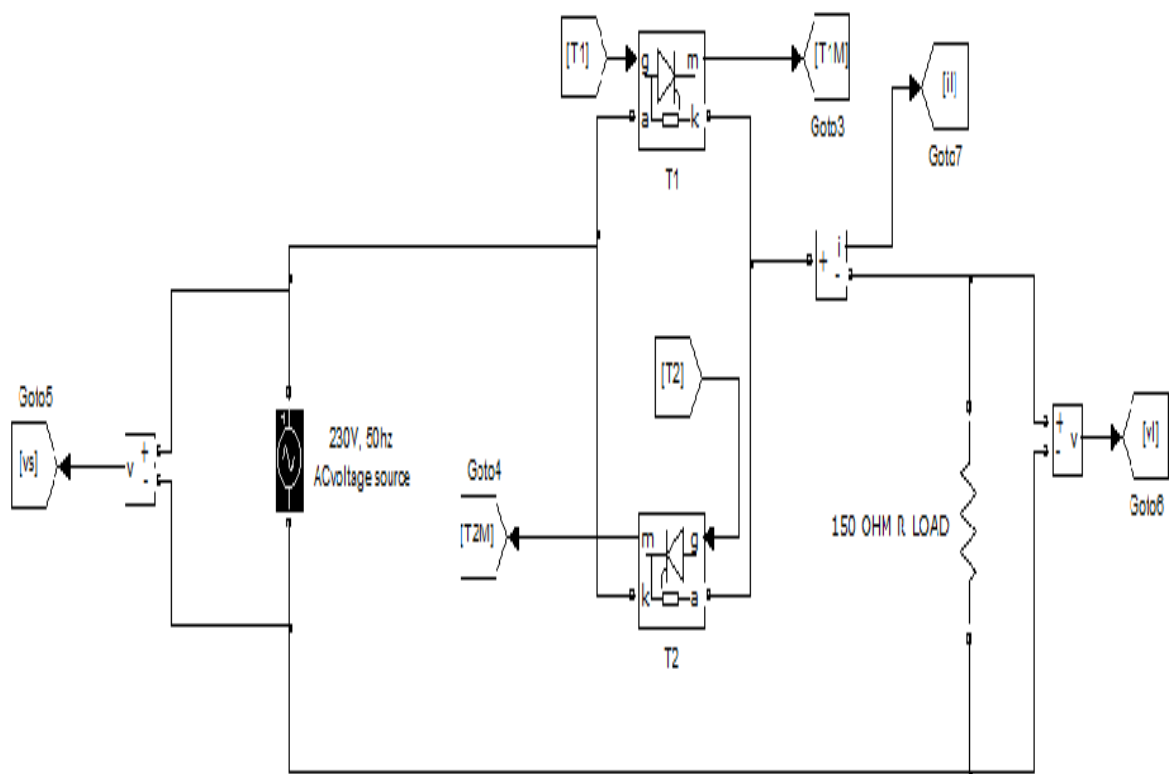
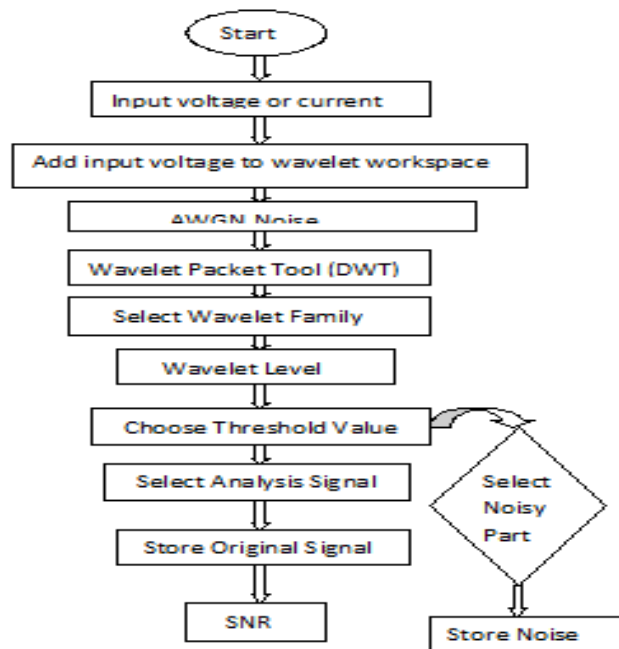

Fig (5) Power System Model

5. ALGORITHM

1. In this paper we design a power system in which we consider an input voltage or current signal.
2. Add the white Gaussian noise (AWGD) in the input voltage.so we get the noisy signal.
3. The noisy signal is employed in Wavelet Packet Tool. Here we select appropriate wavelet family to analyze the waveform in this model. We select (sym) symentic family for accurate result.
4. In this model select sym wavelet level 3 for signal identification and threshold parameter 0.6.
5. Print the result.

6. FLOW CHART



Fig(6) Signal Identification Flow Chart

7. RESULT

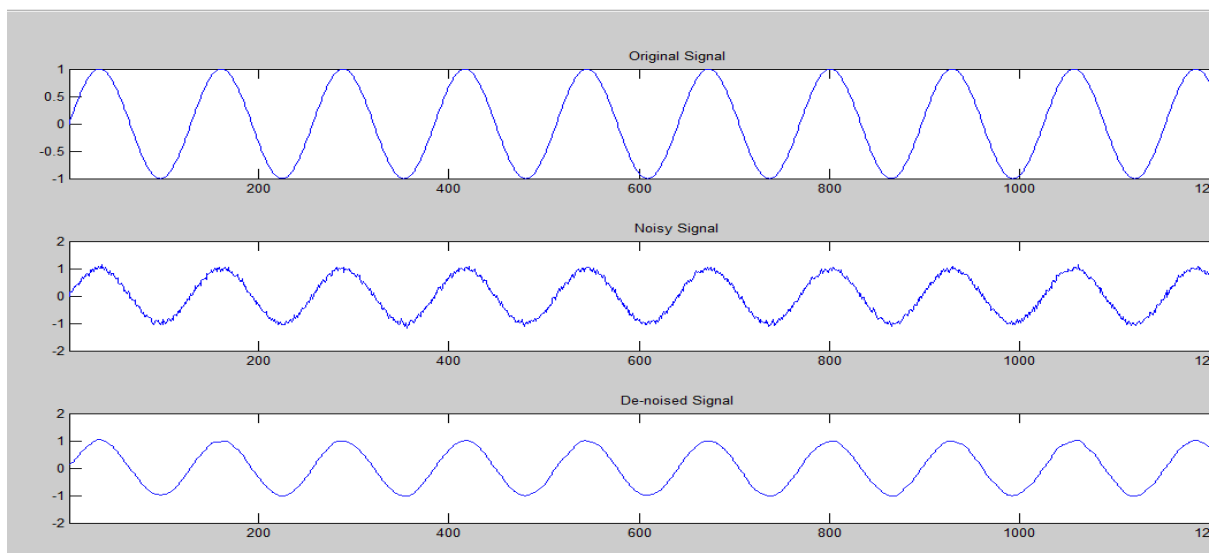

Fig (7)
 (a) Original signal, (b) Noisy signal, (c) Denoised signal

8. CONCLUSION

This paper presents survey on the development of techniques used in power quality identification, which is the major area of research in the field of power system. For detecting power system disturbances wavelet transform have been found to be more robust and effective. From the analysis of the literature it may be concluded;

- One of the promising issues in field of power quality is development of high speed automatic system for the identification, detection and classification of disturbance.

International Journal of Novel Research in Electrical and Mechanical Engineering

 Vol. 2, Issue 2, pp: (83-90), Month: May - August 2015, Available at: www.noveltyjournals.com

- The different techniques of wavelet are used to build new models for identification of power quality events. Thus the scope for future applications includes online monitoring, fault classification and real time control system.

REFERENCES

- [1] Sachin D Ruikar, Dharmpal D Doye “Wavelet Based Image Denoising Technique” (IJACSA) International Journal of Advanced Computer Science and Applications, Vol. 2, No.3, March 2011
- [2] M. Sifuzzaman, M.R. Islam and M.Z. Ali “ Application of Wavelet Transform and its Advantages Compared to Fourier Transform “ Journal of Physical Sciences, Vol. 13, 2009, 121-134 ISSN: 0972-8791 : www.vidyasagar.ac.in/journal
- [3] D. Saxena, S.N. Singh and K.S. Verma Wavelet based denoising of power quality events for characterization International Journal of Engineering, Science and Technology Vol. 3, No. 3, 2011, pp. 119-132
- [4] Yusuf I. Nakhoda, Abraham Lomi, Implementation of dynamic voltage restorer (DVR) and Distribution static compensator (D-Statcom) for power quality improvement cyber journals: Multidisciplinary Journals in science and technology, Journal of selected Area in renewable and sustainable energy (JRSE) May edition 2012.
- [5] Mahesh Singh, Vaibhav Tiwari, “Modeling analysis and solution of Power Quality Problems” international conference on environment electrical engineering 2012.
- [6] Vipul Kumar, Om Shivam, Raj Kumar Sharma, Tanmaya Kumar Patel, “Power Quality Issues, Problems and Solution: Special Feature” International Journal for Research and Development in Engineering (IJRDE)
- [7] www.ijrde.com ISSN: 2279-0500 Special Issue: pp- 143-149
- [8] N.V.H.Ravikumar ,Dr.CH.Sai Babu , K. Durga Syam Prasad,“ Detection and Improvement of Power Quality Disturbances using Wavelet Transform with Noise-Suppression Method” International Journal of Engineering Trends and Technology- Volume3Issue4- 2012
- [9] Ashish Dhiman, “study of wavelet transform in denoising (using Cauchy distribution) IOSR Journal of VLSI and Signal Processing (IOSR-JVSP) Volume 4, Issue 1, Ver. II (Jan. 2014), PP 47-52 e-ISSN: 2319 – 4200, p-ISSN No. : 2319 – 4197
- [10] Dr. M. Sushama, Dr. G. Tulsi Ram, Dr. A. Jaya Laxmi“Detection of Power Quality Disturbances using Wavelet Transforms.
- [11] A. de Almeida, L. Moreira. J. Delgado “Power Quality Problems and New Solutions”.
- [12] Suresh K Gawre,N. P.Patidar, R.K. Nema,“Applications of Wavelet Transform in power Quality:-A Review” International Journal of Computer Application (0975-8887)
- [13] Asem Khmag, AbdRahmanRamli ,ShaifulJahari Hashim, Syed Abdul Rahman Al-Haddad “Review of Image Denoising Algorithms Based on the Wavelet Transformation” International Journal of Advanced Trends in Computer Science and Engineering (IJATCSE), Vol.2 , No.5, Pages : 01-08 (2013)
- [14] V. Kumar , S. K. Gawre, T. Kumar “Power Quality Analysis Using WaveletTransform: A Review” International Conference on Innovations in Engineering and Technology (ICIET’14) ISSN (Online) : 2319 – 8 ISSN (Print) : 2347 - 6710
- [15] P. Karthikeyan, M. Murugappan, and S.Yaacob “ ECG Signal Denoising Using Wavelet Thresholding Techniques in Human Stress Assessment” International Journal on Electrical Engineering and Informatics - Volume 4, Number 2, July 2012
- [16] J.N. Ellinas , T. Mandadelis, A. Tzortzis, L.Aslanoglou. “Image Denoisingusing wavelets”
- [17] Mehmet ÜSTÜNDAĞ, Abdulkadir ŞENGÜR, Muammer GÖKBULUT, Fikret ATA, “Performance comparison of wavelet thresholding techniques on weak ECG signal denoising”
- [18] C Sankaran “POWER QUALITY” The Electrical Power Engineering Series CRC PRESS 2012, Boca Raton London New York Washington, D.C.